

KOŁA ŁAŃCUCHOWE POD TULEJĘ STOŻKOWĄ TAPER LOCK

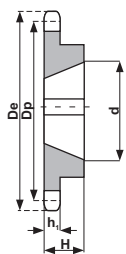

KOŁA ŁAŃCUCHOWE POD TULEJĘ STOŻKOWĄ TAPER LOCK



①

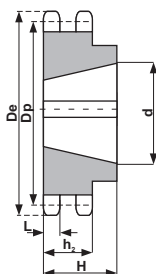

②

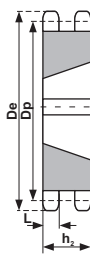

③

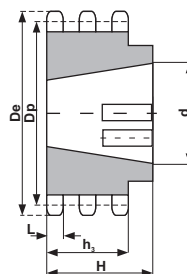

④

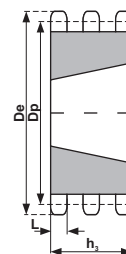

⑤

3/8" x 7/32" 06B - 1-2-3 9,525 x 5,72 mm

ŁAŃCUCH
Podziałka 9,52
Szerokość wew. 5,72
Rolka 6,35

KOŁO ŁAŃCUCHOWE
Promień r 10
Szerokość C 1
Szerokość zęba h_1 5,3
Szerokość zęba L 5,2
Szerokość zęba h_2 15,4
Szerokość zęba h_3 25,6

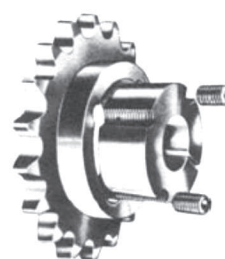

Materiał: Stal C45 E UNI EN 10083-1

Z	De	Dp	1 - rzędowe				2 - rzędowe				3 - rzędowe						
			KOD	d	H	TULEJA	TYP	KOD	d	H	TULEJA	TYP	KOD	d	H	TULEJA	TYP
17	55,3	51,83	TS 05017	45	22	1008	1	TD 05017	41	22	1008	2	TT 05017	-	25,6	1008	5
18	58,3	54,85	TS 05018	45	22	1008	1	TD 05018	43	22	1008	2					
19	61,3	57,87	TS 05019	45	22	1008	1	TD 05019	46	22	1008	2	TT 05019	-	25,6	1008	5
20	64,3	60,89	TS 05020	46	22	1008	1	TD 05020	48	22	1008	2					
21	68,0	63,91	TS 05021	46	22	1008	1	TD 05021	49	22	1008	2	TT 05021	-	25,6	1008	5
22	71,0	66,93	TS 05022	50	22	1108	1	TD 05022	52	22	1108	2					
23	73,5	69,95	TS 05023	63	25	1210	1	TD 05023	59	25	1210	2	TT 05023			1210	5
24	77,0	72,97	TS 05024	63	25	1210	1	TD 05024	61	25	1210	2					
25	80,0	76,02	TS 05025	63	25	1210	1	TD 05025	64	25	1210	2	TT 05025	-	25,6	1210	5
26	83,0	79,02	TS 05026	63	25	1210	1	TD 05026	65	25	1210	2					
27	86,0	82,02	TS 05027	63	25	1210	1	TD 05027	70	25	1210	2	TT 05027	-	25,6	1210	5
28	89,0	85,07	TS 05028	63	25	1210	1	TD 05028	70	25	1210	2					
30	94,7	91,12	TS 05030	63	25	1210	1	TD 05030	75	25	1210	2	TT 05030	79	38	1615	4
38	119,5	115,35	TS 05038	70	25	1210	1	TD 05038	80	25	1610	2	TT 05038	90	38	1615	4
45	140,7	136,55	TS 05045	70	25	1210	1	TD 05045	80	25	1610	2					
57	176,9	172,91	TS 05057	70	25	1210	1	TD 05057	80	25	1610	2					
76	234,9	230,49	TS 05076	70	25	1210	1	TD 05076	80	25	1610	2					
95	292,5	288,08	TS 05095	80	25	1210	1	TD 05095	90	25	1610	2					
114	349,5	345,68	TS 05114	80	38	1215	1	TD 05114	95	38	1615	2					



KOŁA ŁAŃCUCHOWE POD TULEJĘ STOŻKOWĄ TAPER LOCK

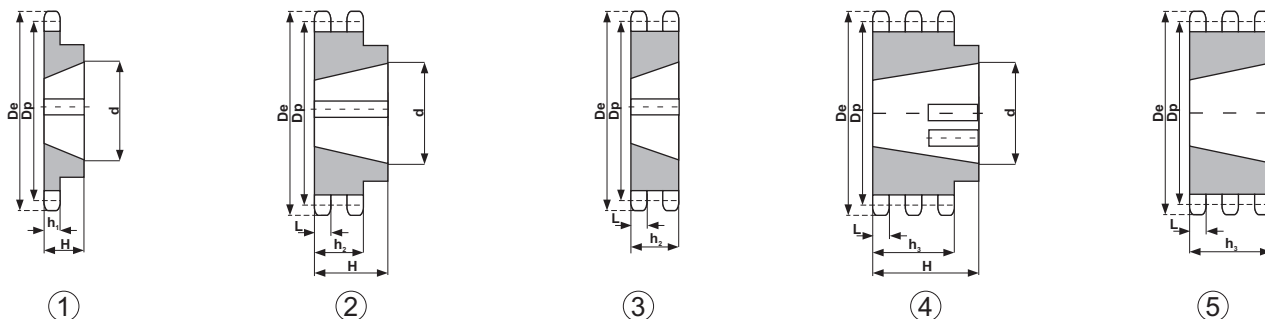

1/2" x 5/16" 12,7 x 7,75 mm - DIN 8187

ŁAŃCUCH
Podziałka 12,0
Szerokość wew. 7,75
Rolka 8,51

KOŁO ŁAŃCUCHOWE
Promień r 13
Szerokość C 1,3
Szerokość zęba h_1 7,2
Szerokość zęba L 7,0
Szerokość zęba h_2 21,0
Szerokość zęba h_3 34,9

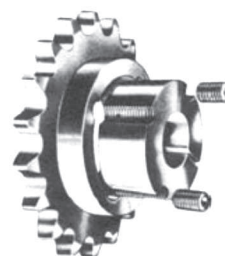

Materiał: Stal C45 E UNI EN 10083-1

Z	De	Dp	1 - rzędowe				2 - rzędowe				3 - rzędowe						
			KOD	d	H	TULEJA	TYP	KOD	d	H	TULEJA	TYP	KOD	d	H	TULEJA	TYP
15	65,5	61,90	TS 09015	45	22	1008	1	TD 09015	46	22	1008	2	TT 09015	-	34,9	1008	5
16	69,5	65,10	TS 09016	50	22	1108	1	TD 09016	50	22	1108	2					
17	73,6	69,11	TS 09017	60	25	1210	1	TD 09017	56	25	1210	2	TT 09017	-	34,9	1210	5
18	77,8	73,14	TS 09018	60	25	1210	1	TD 09018	60	25	1210	2					
19	81,7	77,16	TS 09019	63	25	1210	1	TD 09019	62	25	1210	2	TT 09019	-	34,9	1210	5
20	85,8	81,19	TS 09020	71	25	1610	1	TD 09020	66	25	1610	2					
21	89,7	85,22	TS 09021	71	25	1610	1	TD 05021	70	25	1610	2	TT 09021	-	34,9	1610	5
22	93,8	89,24	TS 09022	71	25	1610	1	TD 09022	76	25	1610	2					
23	98,2	93,27	TS 09023	76	25	1610	1	TD 09023	79	25	1610	2	TT 09023	-	34,9	1610	5
24	101,8	97,29	TS 09024	76	25	1610	1	TD 09024	84	25	1610	2					
25	105,8	101,33	TS 09025	76	25	1610	1	TD 09025	87	32	2012	2	TT 09025	-	34,9	2012	5
26	110,0	105,36	TS 09026	76	25	1610	1	TD 09026	87	32	2012	2					
27	114,4	109,40	TS 09027	76	25	1610	1	TD 09027	87	32	2012	2	TT 09027	-	34,9	2012	5
28	118,0	113,42	TS 09028	90	32	2012	1	TD 09028	87	32	2012	2					
30	126,1	121,50	TS 09030	90	32	2012	1	TD 09030	87	32	2012	2	TT 09030	-	34,9	2012	5
38	158,6	153,80	TS 09038	90	32	2012	1	TD 09038	100	32	2012	2	TT 09038	-	34,9	2012	5
45	188,0	182,07	TS 09045	100	32	2012	1	TD 09045	100	32	2012	2					
57	236,4	230,54	TS 09057	100	32	2012	1	TD 09057	100	32	2012	2					
76	313,3	307,33	TS 09076	100	32	2012	1	TD 09076	100	32	2012	2					
95	390,1	384,11	TS 09095	100	32	2012	1	TD 09095	100	32	2012	2					
114	466,9	460,90	TS 09114	110	45	2017	1	TD 09114	110	45	2517	2					



ATLANTIS
TWOJ DOSTAWCA ELEMENTÓW PRZENIESIENIA NAPĘDU

KOŁA ŁAŃCUCHOWE POD TULEJĘ STOŻKOWĄ TAPER LOCK

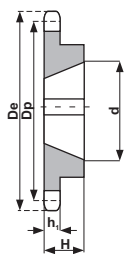

①

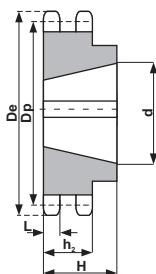

②

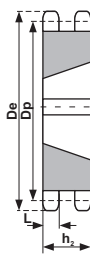

③

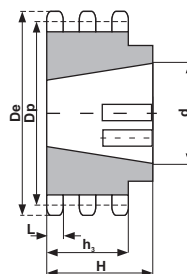

④

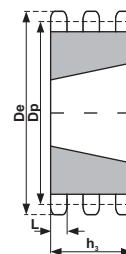

⑤

5/8" x 3/8" 10B - 1-2-3 15,875 x 9,65 mm

ŁAŃCUCH

Podziałka	15,87
Szerokość wew.	9,650
Rolka	10,16

ISO

mm

KOŁO ŁAŃCUCHOWE

Promień r	r	16
Szerokość C	C	1,6
Szerokość zęba h_1	h_1	9,1
Szerokość zęba L	L	9,0
Szerokość zęba h_2	h_2	25,5
Szerokość zęba h_3	h_3	42,1

ISO

mm

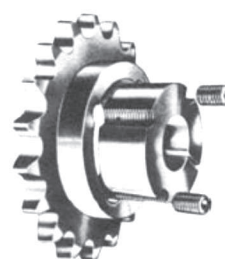

Materiał: Stal C45 E UNI EN 10083-1

Z	De	Dp	1 - rzędowe					2 - rzędowe					3 - rzędowe				
			KOD	d	H	TULEJA	TYP	KOD	d	H	TULEJA	TYP	KOD	d	H	TULEJA	TYP
13	73,0	66,32	TS 10013	47	22	1008	1	TD 10013	-	25,5	1210	3					
14	78,0	71,34	TS 10014	52	22	1108	1										
15	83,0	76,36	TS 10015	60	25	1210	1	TD 10015	-	25,5	1210	3	TT 10015	-	42,1	1210	5
16	88,0	81,37	TS 10016	70	25	1610	1										
17	93,0	86,36	TS 10017	71	25	1610	1	TD 10017	-	25,5	1610	3	TT 10017	-	42,1	1210	5
18	98,3	91,42	TS 10018	75	25	1610	1										
19	103,3	96,45	TS 10019	75	25	1610	1	TD 10019	-	25,5	1610	3	TT 10019	-	42,1	1615	5
20	108,4	101,49	TS 10020	75	25	1610	1	TD 10020	-	25,5	1610	3					
21	113,4	106,52	TS 10021	76	25	1610	1	TD 10021	-	25,5	1610	3	TT 10021	-	42,1	1615	5
22	118,0	111,55	TS 10022	76	25	1610	1	TD 10022	-	25,5	1610	3					
23	123,4	116,58	TS 10023	76	25	1610	1	TD 10023	-	25,5	1610	3	TT 10023	-	42,1	2012	5
24	128,3	121,62	TS 10024	90	32	2012	1										
25	134,0	126,66	TS 10025	90	32	2012	1	TD 10025	90	32,0	2012	2	TT 10025	105	45,0	2517	4
26	139,0	131,70	TS 10026	90	32	2012	1										
27	144,0	136,75	TS 10027	90	32	2012	1	TD 10027	90	32,0	2012	2	TT 10027	110	45,0	2517	4
28	148,7	141,78	TS 10028	90	32	2012	1										
30	158,8	151,87	TS 10030	90	32	2012	1	TD 10030	90	32,0	2012	2	TT 10030	120	45,0	2517	4
38	199,2	192,24	TS 10038	100	32	2012	1	TD 10038	108	45,0	2517	2					
45	235,0	227,58	TS 10045	100	32	2012	1										
57	296,0	288,18	TS 10057	100	32	2012	1										
76	392,1	384,16	TS 10076	100	32	2012	1										
95	488,5	480,14	TS 10095	110	45	2517	1										
114	584,1	576,13	TS 10114	110	45	2517	1										



KOŁA ŁAŃCUCHOWE POD TULEJĘ STOŻKOWĄ TAPER LOCK

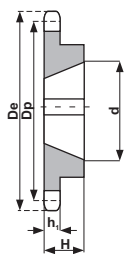

①

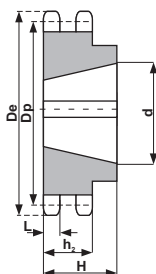

②

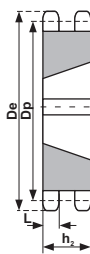

③

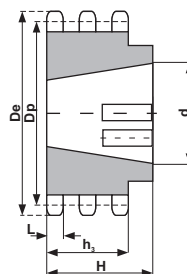

④

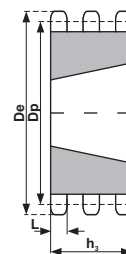

⑤

3/4" x 7/16" 12B - 1-2-3 19,05 x 11,68 mm

ŁAŃCUCH	ISO
	mm
Podziałka	19,0
Szerokość wew.	11,6
Rolka	12,0

KOŁO ŁAŃCUCHOWE	ISO
	mm
Promień r	r
Szerokość C	C
Szerokość zęba h_1	h_1
Szerokość zęba L	L
Szerokość zęba h_2	h_2
Szerokość zęba h_3	h_3

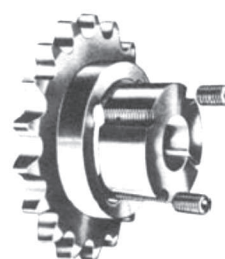

Materiał: Stal C45 E UNI EN 10083-1

Z	De	Dp	1 - rzędowe					2 - rzędowe					3 - rzędowe					
			KOD	d	H	TULEJA	TYP	KOD	d	H	TULEJA	TYP	KOD	d	H	TULEJA	TYP	
13	87,5	79,59	TS 11013	60	25	1210	1											
14	93,6	85,61	TS 11014	70	25	1610	1											
15	99,8	91,63	TS 11015	70	25	1610	1	TD 11015	-	30,3	1610	3	TT 11015	-	49,8	1615	5	
16	105,5	97,65	TS 11016	75	25	1610	1	TD 11016	-	30,3	1610	3						
17	111,5	103,67	TS 11017	76	25	1610	1	TD 11017	-	30,3	1610	3	TT 11017	-	49,8	2012	5	
18	118,0	109,71	TS 11018	90	32	2012	1	TD 11018	90	32	2012	2						
19	124,2	115,75	TS 11019	90	32	2012	1	TD 11019	90	32	2012	2	TT 11019	-	49,8	2012	5	
20	129,7	121,78	TS 11020	90	32	2012	1	TD 11020	108	45	2517	2						
21	136,0	127,82	TS 11021	102	45	2517	1	TD 11021	108	45	2517	2	TT 11021	-	49,8	2517	5	
22	141,8	133,86	TS 11022	102	45	2517	1	TD 11022	108	45	2517	2						
23	149,0	139,90	TS 11023	108	45	2517	1	TD 11023	108	45	2517	2	TT 11023	-	49,8	2517	5	
24	153,9	145,94	TS 11024	108	45	2517	1	TD 11024	108	45	2517	2						
25	160,0	152,00	TS 11025	108	45	2517	1	TD 11025	108	45	2517	2	TT 11025	-	49,8	2517	5	
26	165,9	158,04	TS 11026	108	45	2517	1	TD 11026	108	45	2517	2						
27	172,3	164,00	TS 11027	108	45	2517	1	TD 11027	108	45	2517	2	TT 11027	140	51	3020	4	
28	178,0	170,13	TS 11028	108	45	2517	1	TD 11028	108	45	2517	2						
30	190,5	182,25	TS 11030	108	45	2517	1	TD 11030	108	45	2517	2	TT 11030	140	51	3020	4	
38	239,0	230,69	TS 11038	108	45	2517	1	TD 11038	140	51	3020	2	TT 11038	140	51	3020	4	
45	282,5	273,10	TS 11045	108	45	2517	1	TD 11045	140	51	3020	2	TT 11045	140	51	3020	4	
57	355,4	345,81	TS 11057	108	45	2517	1	TD 11057	140	51	3020	2	TT 11057	140	51	3020	4	
76	469,9	460,99	TS 11076	108	45	2517	1	TD 11076	140	51	3020	2	TT 11076	140	51	3020	4	
95	585,1	576,17	TS 11095	108	45	2517	1	TD 11095	140	51	3020	2						
114	700,6	691,36	TS 1111 4	108	64	2525	1											



KOŁA ŁAŃCUCHOWE POD TULEJĘ STOŻKOWĄ TAPER LOCK

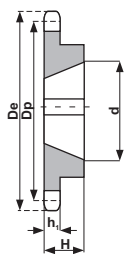

①

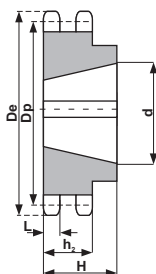

②

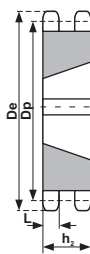

③

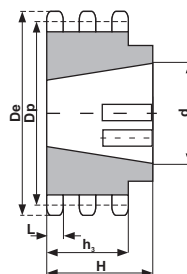

④

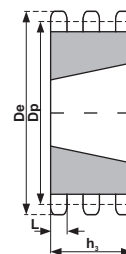

⑤

1" x 17,02 mm 16B - 1-2-3 25,4 x 17,2 mm

ŁAŃCUCH	ISO
Podziałka	mm
Szerokość wew.	25,4
Rolka	17,0
	15,8

KOŁO ŁAŃCUCHOWE	ISO
Promień r	mm
Szerokość C	26,0
Szerokość zęba h_1	C
Szerokość zęba L	2,5
Szerokość zęba h_2	h_1
Szerokość zęba h_3	L
	15,8
	h_2
	47,7
	h_3
	79,6

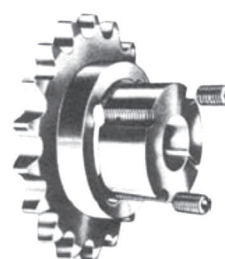

Material: Stal C45 E UNI EN 10083-1

Z	De	Dp	1 - rzędowe					2 - rzędowe					3 - rzędowe				
			KOD	d	H	TULEJA	TYP	KOD	d	H	TULEJA	TYP	KOD	d	H	TULEJA	TYP
13	117,0	106,12	TS 12013	73	25	1610	1	TD 12013	-	47,7	2012	3					
14	125,0	114,15	TS 12014	76	25	1610	1										
15	133,0	122,17	TS 12015	76	25	1610	1	TD 12015	-	47,7	2012	3					
16	141,0	130,20	TS 12016	90	32	2012	1										
17	149,0	138,22	TS 12017	90	32	2012	1	TD 12017	-	47,7	2517	3	TT 12017	-	79,6	2517	5
18	157,0	146,28	TS 12018	108	45	2517	1										
19	165,2	154,33	TS 12019	108	45	2517	1	TD 12019	-	47,7	2517	3	TT 12019	-	79,6	3020	5
20	173,2	162,38	TS 12020	108	45	2517	1										
21	181,2	170,43	TS 12021	110	45	2517	1	TD 12021	140	51	3020	2	TT 12021	-	79,6	3030	5
22	189,3	178,48	TS 12022	110	45	2517	1										
23	197,5	186,53	TS 12023	110	45	2517	1	TD 12023	140	51	3020	2	TT 12023	-	79,6	3525	5
24	205,5	194,59	TS 12024	110	45	2517	1										
25	213,5	202,66	TS 12025	110	45	2517	1	TD 12025	140	51	3020	2	TT 12025	-	79,6	3525	5
26	221,6	210,72	TS 12026	110	45	2517	1										
27	229,6	218,79	TS 12027	110	45	2517	1	TD 12027	140	51	3020	2	TT 12027	-	79,6	3525	5
28	237,7	226,85	TS 12028	110	45	2517	1										
30	254,0	243,00	TS 12030	140	51	3020	1	TD 12030	140	51	3020	2	TT 12030	-	79,6	3525	5
38	320,7	307,59	TS 12038	140	51	3020	1	TD 12038	140	51	3020	2	TT 12038	-	79,6	3525	5
45	377,1	364,13	TS 12045	140	51	3020	1	TD 12045	140	51	3020	2	TT 12045	216	79,6	4030	4
57	474,0	461,07	TS 12057	140	51	3020	1	TD 12057	175	65	3525	2	TT 12057	216	79,6	4030	4
76	627,0	614,65	TS 12076	140	51	3020	1	TD 12076	175	65	3525	2	TT 12076	216	79,6	4030	4
95	781,1	768,22	TS 12095	140	51	3020	1	TD 12095	215	65	3525	2	TT 12095	240	79,6	4030	4
114	934,3	921,81	TS 12114	140	76	3030	1	TD 12114	215	102	4040	2					



KOŁA ŁAŃCUCHOWE POD TULEJĘ STOŻKOWĄ TAPER LOCK

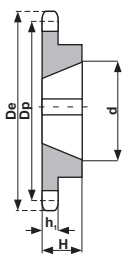

①

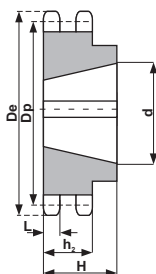

②

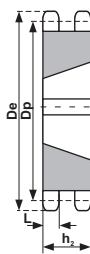

③

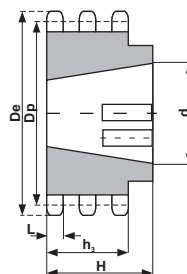

④

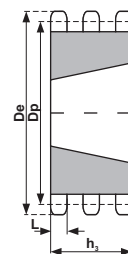

⑤

1" 1/4 x 3/4" 20B - 1-2-3 31,75 x 19,56 mm

ŁAŃCUCH		ISO
Podziałka		mm
Szerokość wew.		31,7
Rolka		19,5
		19,0

KOŁO ŁAŃCUCHOWE		ISO
Promień r	r	mm
Szerokość C	C	32,0
Szerokość zęba h_1	h_1	3,5
Szerokość zęba L	L	18,5
Szerokość zęba h_2	h_2	18,2
Szerokość zęba h_3	h_3	54,6
		91

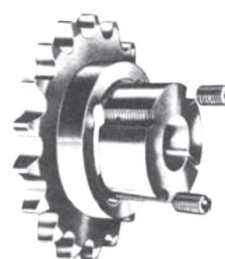

Materiał: Stal C45 E UNI EN 10083-1

Z	De	Dp	1 - rzędowe				
			KOD	d	H	TULEJA	TYP
13	147,8	132,65	TS 13013	90	32	2012	1
14	157,8	142,68	TS 13014	90	32	2012	1
15	167,9	152,72	TS 13015	108	45	2517	1
16	177,9	162,75	TS 13016	108	45	2517	1
17	187,9	172,78	TS 13017	108	45	2517	1
18	198,0	182,85	TS 13018	108	45	2517	1
19	208,1	192,91	TS 13019	108	45	2517	1
20	218,1	202,98	TS 13020	108	45	2517	1
21	228,2	213,04	TS 13021	108	45	2517	1
22	238,3	223,11	TS 13022	108	45	2517	1
23	248,3	233,17	TS 13023	108	45	2517	1
24	258,4	243,23	TS 13024	108	45	2517	1
25	268,5	253,33	TS 13025	108	45	2517	1
27	288,6	273,40	TS 13027	150	51	3020	1
30	318,9	303,75	TS 13030	150	51	3020	1
38	399,6	384,49	TS 13038	160	51	3020	1
45	470,3	455,17	TS 13045	160	51	3020	1
57	591,5	576,36	TS 13057	160	51	3020	1
76	783,5	768,32	TS 13076	160	51	3020	1



KOŁA ŁAŃCUCHOWE POD TULEJĘ STOŻKOWĄ TAPER LOCK Z UTWARDZONYMI INDUKCYJNIE ZĘBAMI

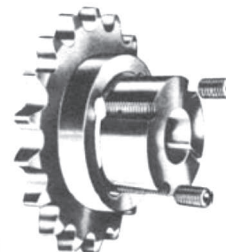
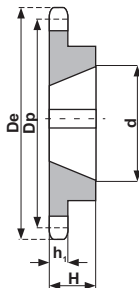

Materiał: Stal C45 E UNI EN 10083-1

3/8" x 7/32" - 06B R. 6,35

Z	De	Dp	1- rzędowe				
			KOD	d	H	TULEJA	TYP
17	55,3	51,83	TS 05T17	45	22	1008	1
18	58,3	54,85	TS 05T18	45	22	1008	1
19	61,3	57,87	TS 05T19	45	22	1008	1
20	64,3	60,89	TS 05T20	46	22	1008	1
21	68,0	63,91	TS 05T21	46	22	1008	1
22	71,0	66,93	TS 05T22	50	22	1008	1
23	73,5	69,95	TS 05T23	63	25	1210	1
24	77,0	72,97	TS 05T24	63	25	1210	1
25	80,0	76,02	TS 05T25	63	25	1210	1
26	83,0	79,02	TS 05T26	63	25	1210	1
27	86,0	82,02	TS 05T27	63	25	1210	1
28	89,0	85,07	TS 05T28	63	25	1210	1
30	94,7	91,12	TS 05T30	63	25	1210	1

1/2" x 5/16" - 08B R. 8,51

Z	De	Dp	1- rzędowe				
			KOD	d	H	TULEJA	TYP
15	65,5	61,90	TS 09T15	45	22	1008	1
16	69,5	65,10	TS 09T16	50	22	1108	1
17	73,6	69,11	TS 09T17	60	25	1210	1
18	77,8	73,14	TS 09T18	60	25	1210	1
19	81,7	77,16	TS 09T19	63	25	1210	1
20	85,8	81,19	TS 09T20	71	25	1610	1
21	89,7	85,22	TS 09T21	71	25	1610	1
22	93,8	89,24	TS 09T22	71	25	1610	1
23	98,2	93,27	TS 09T23	76	25	1610	1
24	101,8	97,29	TS 09T24	76	25	1610	1
25	105,8	101,33	TS 09T25	76	25	1610	1
26	110,0	105,36	TS 09T26	76	25	1610	1
27	114,4	109,40	TS 09T27	76	25	1610	1
28	118,0	113,42	TS 09T28	90	32	2012	1
30	126,1	121,50	TS 09T30	90	32	2012	1

5/8" x 3/8" - 10B R. 10,16

Z	De	Dp	1- rzędowe				
			KOD	d	H	TULEJA	TYP
13	73,0	66,32	TS 10T13	47	22	1008	1
14	78,0	71,34	TS 10T14	52	22	1108	1
15	83,0	76,36	TS 10T15	60	25	1210	1
16	88,0	81,37	TS 10T16	70	25	1610	1
17	93,0	86,36	TS 10T17	71	25	1610	1
18	98,3	91,42	TS 10T18	75	25	1610	1
19	103,3	96,45	TS 10T19	75	25	1610	1
20	108,4	101,49	TS 10T20	75	25	1610	1
21	113,4	106,52	TS 10T21	76	25	1610	1
22	118,0	111,55	TS 10T22	76	25	1610	1
23	123,4	116,58	TS 10T23	76	25	1610	1
24	128,3	121,62	TS 10T24	90	32	1610	1
25	134,0	126,66	TS 10T25	90	32	2012	1
26	139,0	131,70	TS 10T26	90	32	2012	1
27	144,0	136,75	TS 10T27	90	32	2012	1
28	148,7	141,78	TS 10T28	90	32	2012	1
30	158,8	151,87	TS 10T30	90	32	2012	1

3/4" x 7/16" - 12B R. 12,07

Z	De	Dp	1- rzędowe				
			KOD	d	H	TULEJA	TYP
13	87,5	79,59	TS 11T13	60	25	1210	1
14	93,6	85,61	TS 11T14	70	25	1610	1
15	99,8	91,63	TS 11T15	70	25	1610	1
16	105,5	97,65	TS 11T16	75	25	1610	1
17	111,5	103,67	TS 11T17	76	25	1610	1
18	118,0	109,71	TS 11T18	90	32	2012	1
19	124,2	115,75	TS 11T19	90	32	2012	1
20	129,7	121,78	TS 11T20	90	32	2012	1
21	136,0	127,82	TS 11T21	102	45	2517	1
22	141,8	133,86	TS 11T22	102	45	2517	1
23	149,0	139,90	TS 11T23	108	45	2517	1
24	153,9	145,94	TS 11T24	108	45	2517	1
25	160,0	152,00	TS 11T25	108	45	2517	1
26	165,9	158,04	TS 11T26	108	45	2517	1
27	172,3	164,00	TS 11T27	108	45	2517	1
28	178,0	170,13	TS 11T28	108	45	2517	1
30	190,5	182,25	TS 11T30	108	45	2517	1

1" x 17/32" - 16B R. 15,88

Z	De	Dp	1- rzędowe				
			KOD	d	H	TULEJA	TYP
13	117,0	106,12	TS 12T13	73	25	1610	1
14	125,0	114,15	TS 12T14	76	25	1610	1
15	133,0	122,17	TS 12T15	76	25	1610	1
16	141,0	130,20	TS 12T16	90	32	2012	1
17	149,0	138,22	TS 12T17	90	32	2012	1
18	157,0	146,28	TS 12T18	108	45	2517	1
19	165,2	154,33	TS 12T19	108	45	2517	1
20	173,2	162,38	TS 12T20	108	45	2517	1
21	181,2	170,43	TS 12T21	110	45	2517	1
22	189,3	178,48	TS 12T22	110	45	2517	1
23	197,5	186,53	TS 12T23	110	45	2517	1
24	205,5	194,59	TS 12T24	110	45	2517	1
25	213,5	202,66	TS 12T25	110	45	2517	1
26	221,6	210,72	TS 12T26	110	45	2517	1
27	229,6	218,79	TS 12T27	110	45	2517	1

1" 1/4 x 3/4" - 20B R. 19,05

Z	De	Dp	1- rzędowe				
			KOD	d	H	TULEJA	TYP
13	147,8	132,65	TS 13T13	90	32	2012	1
15	167,9	152,72	TS 13T15	108	45	2517	1
17	187,9	172,78	TS 13T17	108	45	2517	1
19	208,1	192,91	TS 13T19	108	45	2517	1
21	228,2	213,04	TS 13T21	108	45	2517	1
23	248,3	233,17	TS 13T23	108	45	2517	1
25	268,5	253,33	TS 13T25	108	45	2517	1
27	288,6	273,40	TS 13T27	150	51	3020	1
30	318,9	303,75	TS 13T30	150	51	3020	1

